

COTAS ROJAS	P.K.		DISTANCIAS AL ORIGEN	DISTANCIAS PARCIALES	COTAS DE PROYECTO	COTAS DE TERRENO	TERRAPLEN	DESMONTE
	Inicio	Fin						
	0	10	0.00	10.00	911.34	911.01	0.33	
	10	20	10.00	20.00	911.34	910.97	0.37	
	20	30	20.00	30.00	911.34	910.80	0.54	
	30	40	30.00	40.00	911.37	910.87	0.50	
	40	50	40.00	50.00	911.47	910.85	0.62	
	50	60	50.00	60.00	911.57	910.81	0.76	
	60	70	60.00	70.00	911.57	910.77	0.80	
	70	80	70.00	80.00	911.67	910.73	0.94	
	80	90	80.00	90.00	911.72	910.70	1.02	
	90	100	90.00	100.00	911.77	910.71	1.06	
	100	110	100.00	110.00	911.83	910.78	1.05	
	110	120	110.00	120.00	911.83	910.81	1.03	
	120	130	120.00	130.00	911.83	910.80	1.03	
	130	140	130.00	140.00	911.83	910.84	1.02	
	140	150	140.00	150.00	911.77	911.05	0.72	
	150	160	150.00	160.00	911.77	911.15	0.62	
	160	170	160.00	170.00	911.77	911.25	0.52	
	170	180	170.00	180.00	911.82	911.39	0.43	
	180	190	180.00	190.00	911.82	911.57	0.25	
	190	200	190.00	200.00	911.82	911.77	0.05	
	200	210	200.00	210.00	911.82	911.99	-0.17	
	210	220	210.00	220.00	911.82	912.23	-0.41	
	220	230	220.00	230.00	911.82	912.50	-0.68	
	230	240	230.00	240.00	911.82	912.80	-1.00	
	240	250	240.00	250.00	911.82	913.17	-1.35	
	250	260	250.00	260.00	911.82	913.60	-1.78	
	260	270	260.00	270.00	911.82	914.08	-2.26	
	270	280	270.00	280.00	911.82	914.28	-2.46	
	280	290	280.00	290.00	911.82	914.41	-2.60	
	290	300	290.00	300.00	911.82	914.50	-2.68	
	300	310	300.00	310.00	911.82	914.57	-2.75	
	310	320	310.00	320.00	911.82	914.62	-2.80	
	320	330	320.00	330.00	911.82	914.65	-2.83	
	330	340	330.00	340.00	911.82	914.66	-2.84	
	340	350	340.00	350.00	911.82	914.66	-2.84	
	350	360	350.00	360.00	911.82	914.65	-2.85	
	360	370	360.00	370.00	911.82	914.62	-2.88	
	370	380	370.00	380.00	911.82	914.57	-2.95	
	380	390	380.00	390.00	911.82	914.50	-3.02	
	390	400	390.00	400.00	911.82	914.41	-3.11	
	400	410	400.00	410.00	911.82	914.30	-3.22	
	410	420	410.00	420.00	911.82	914.17	-3.35	
	420	429	420.00	429.00	911.82	914.00	-3.52	

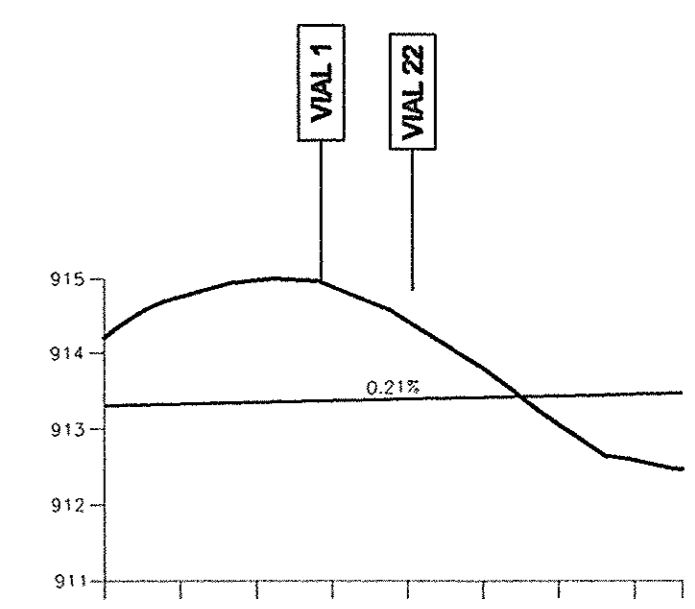

COTAS ROJAS	P.K.		DISTANCIAS AL ORIGEN	DISTANCIAS PARCIALES	COTAS DE PROYECTO	COTAS DE TERRENO	TERRAPLEN	DESMONTE
	Inicio	Fin						
	0	10	0.00	10.00	913.31	914.20	-0.89	
	10	20	10.00	20.00	913.33	914.74	-1.41	
	20	30	20.00	30.00	913.35	914.85	-1.50	
	30	40	30.00	40.00	913.37	914.87	-1.50	
	40	50	40.00	50.00	913.39	914.42	-1.03	
	50	60	50.00	60.00	913.41	913.80	-0.39	
	60	70	60.00	70.00	913.44	913.07	0.37	
	70	76	70.00	76.27	913.46	912.58	0.87	
	76	76	76.27	76.27	913.47	912.46	1.01	

VIAL - 22

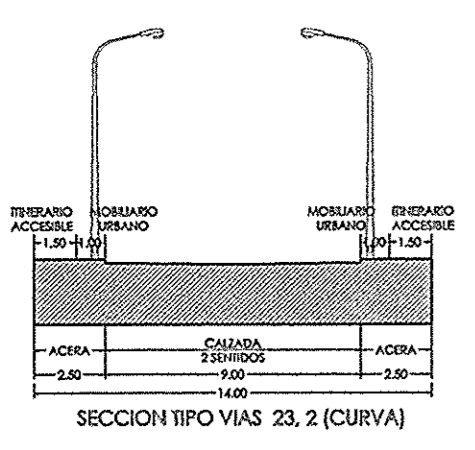
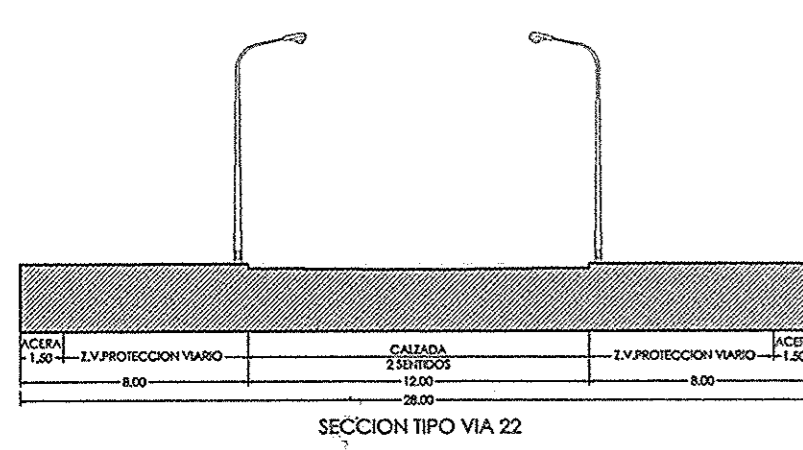

COTAS ROJAS	P.K.		DISTANCIAS AL ORIGEN	DISTANCIAS PARCIALES	COTAS DE PROYECTO	COTAS DE TERRENO	TERRAPLEN	DESMONTE
	Inicio	Fin						
	0	10	0.00	10.00	916.13	916.64	-0.51	
	10	20	10.00	20.00	915.65	915.95	-0.31	
	20	30	20.00	30.00	915.17	915.24	-0.07	
	30	40	30.00	40.00	914.69	914.52	0.17	
	40	50	40.00	50.00	914.20	913.92	0.28	
	50	60	50.00	60.00	913.89	913.52	0.37	
	60	70	60.00	70.00	913.61	913.26	0.35	
	70	80	70.00	80.00	913.36	912.98	0.38	
	80	90	80.00	90.00	913.11	912.72	0.39	
	90	100	90.00	100.00	912.88	912.48	0.40	
	100	110	100.00	110.00	912.66	912.14	0.52	
	110	120	110.00	120.00	912.44	911.80	0.64	
	120	130	120.00	130.00	912.24	911.44	0.80	
	130	140	130.00	140.00	912.03	911.06	0.97	
	140	150	140.00	150.00	911.82	910.65	1.17	
	150	160	150.00	160.00	911.61	910.19	1.42	
	160	170	160.00	170.00	911.40	910.00	1.40	
	170	180	170.00	180.00	911.19	910.00	1.19	
	180	190	180.00	190.00	910.99	910.00	0.99	
	190	200	190.00	200.00	910.79	910.00	0.79	
	200	210	200.00	210.00	910.59	910.00	0.59	
	210	220	210.00	220.00	910.39	910.00	0.39	
	220	230	220.00	230.00	910.19	910.00	0.19	
	230	240	230.00	240.00	910.00	910.00	0.00	
	240	250	240.00	250.00	910.00	910.00	0.00	
	250	260	250.00	260.00	910.00	910.00	0.00	
	260	270	260.00	270.00	910.00	910.00	0.00	
	270	280	270.00	280.00	910.00	910.00	0.00	
	280	280	280.00	280.00	910.00	910.00	0.00	

VIAL - 23

Glorieta 2

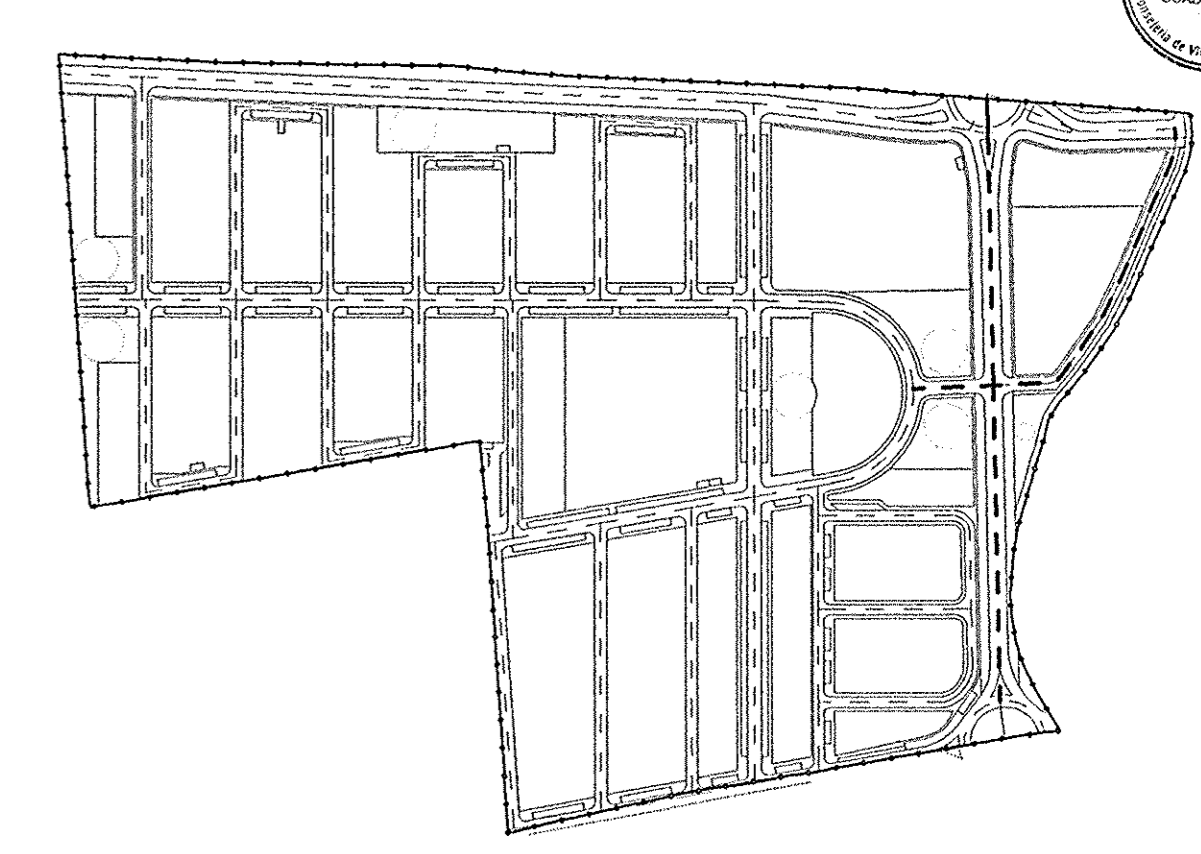

ALTERNATIVA TECNICA
SECTORES 15 y 16
De Suelo Urbanizable del P.O.M. de Horche, Gu.

VIARIO			
Perfiles Longitudinales			
Viiales 22, 23 y Glorieta 2			
escalas horiz 1:1.000 vertical 1:100	0205/B06	Sep/05	

0.13

Arquitecto:	Promotor:
LUS MONTALVO DE LA BLANCA	P.P. D.



Distancia - Aprobado definitivamente por el Pleno del Ayuntamiento en sesión extraordinaria celebrada el día 5 de marzo de 2.007
Horche, 20 de marzo de 2.007

